



# **HYSUCAT**

**HYDROFOIL TECHNOLOGY**



HYSUCAT, an acronym for **H**ydrofoil **S**upported **C**atamaran, is the combination of a distinctively designed hull and foil incorporating hydrofoil science and technology.



# HYSUCAT TECHNOLOGY

The basic principle behind the Hysucat is an effective hydrofoil system in the tunnel between two demi-hulls. This consists of a main wing located in front of the length emphasis in keel height, supported by two smaller wings in the tunnel at the rear of the hull.

## **HYDROFOIL ADVANTAGES**

- Higher top speed
- Improved sea keeping in rough seas
- Reduced fuel consumption
- Increased range due to lower fuel consumption
- Wave dampening
- Dry ride
- Improved load

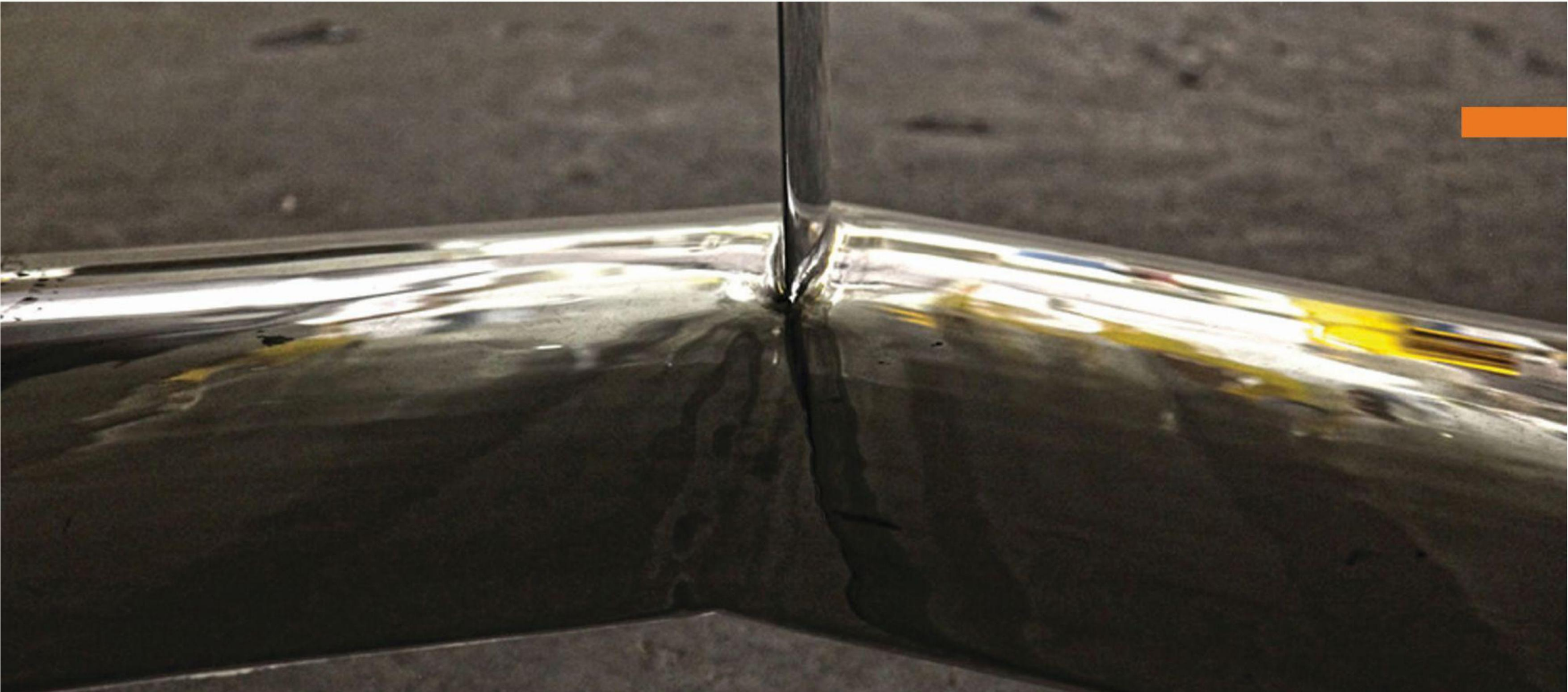

# HYSUCAT CC30



# ABOUT

**HYSUCAT 30' Center Console Sport Fisher** offers the best features of a monohull and a catamaran combined yet made superior thanks to innovative hydrofoil technology. Designed by renowned hydrofoil specialist Malan Conradie, the Hysucat patented, high-performance asymmetric catamaran is capable of delivering higher speed with less horsepower, a soft, comfortable, stable ride in waves or swells, and efficient, reduced fuel consumption.

The layout creates an air tunnel under the hull, providing a better ride and increased speed. This center-console's 9-foot, 6-inch beam offers an extraordinary amount of fishing space, while the unsinkable design offers boating anglers great peace of mind.

Loaded with standard features, the Hysucat 30 Center Console combines hard-core fishing essentials with luxury and comfort. Wrap-around bow seating with optional chaise lounge and removable table are great for a family day on the water. Anglers will appreciate the standard fiberglass lean post, deluxe tackle center, rod holders, footrest and flip-up bolster chairs. There is plenty of storage with port and starboard insulated fish boxes/storage along with an enclosed head.

Boasting 264-gallon fuel capacity, this boat will get you to the farthest fishing grounds and back with speed and comfort.



# STANDARD LAYOUT

HYSUCAT 30' Sport Fisher

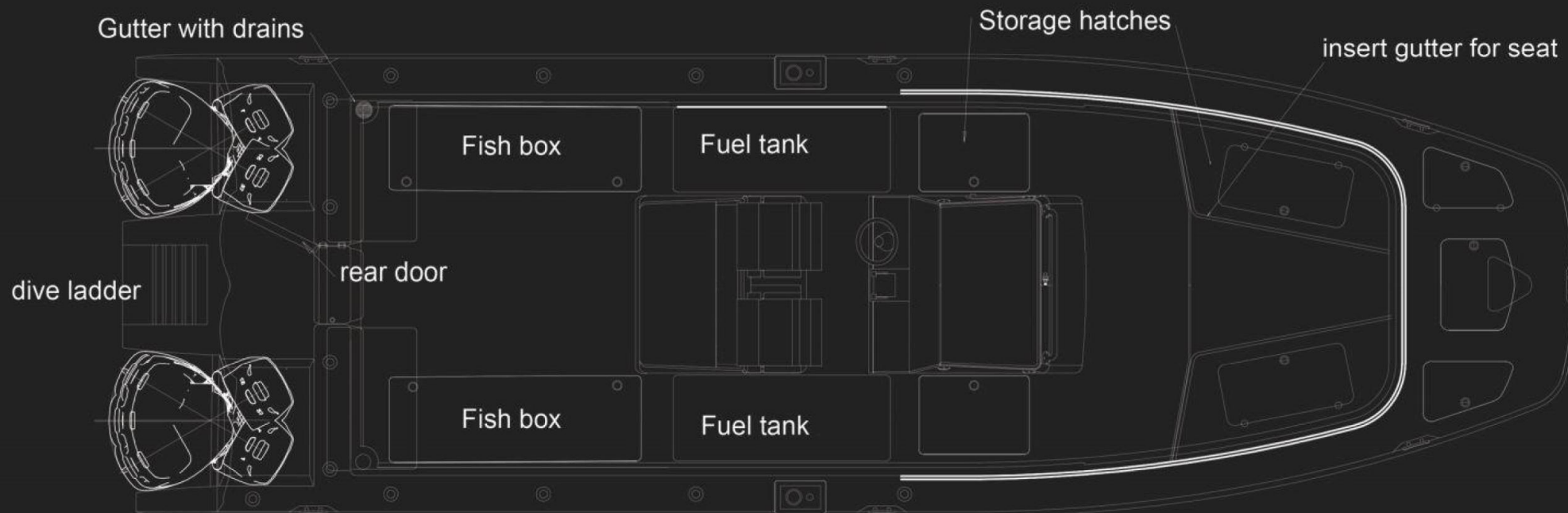
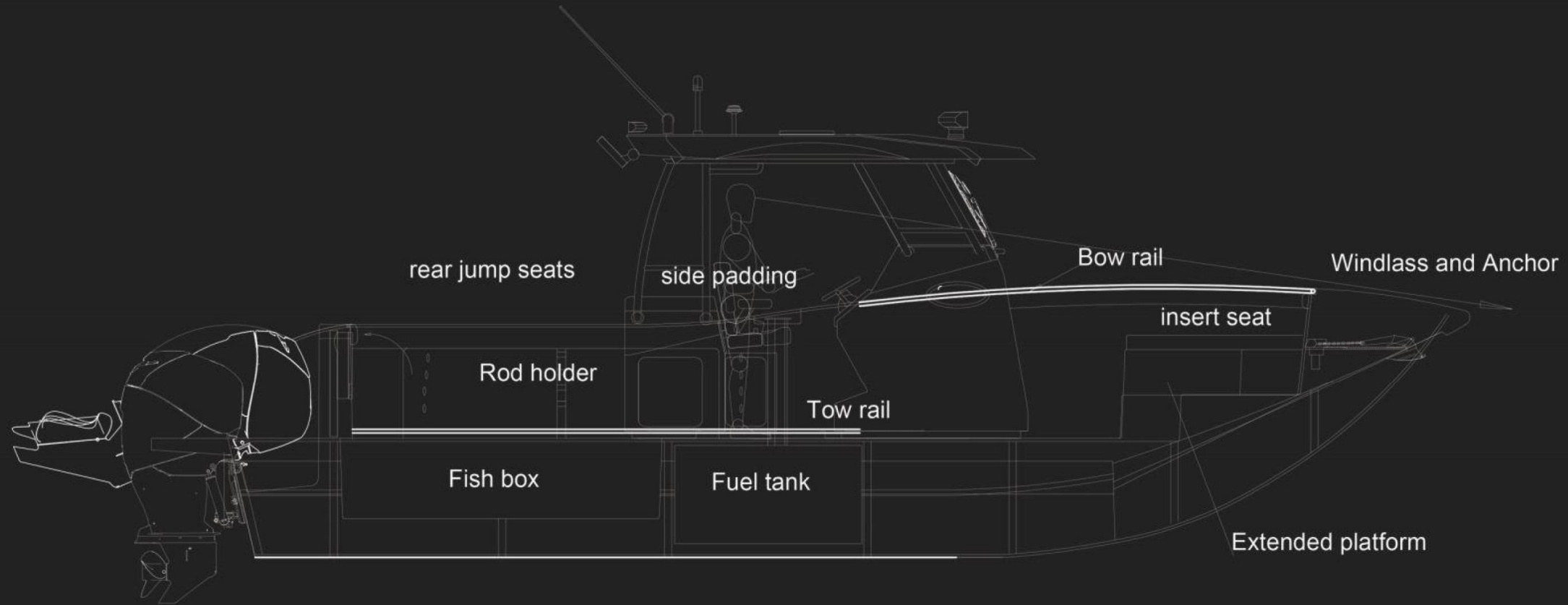

# STANDARD SPECIFICATIONS

LOA – 30'4" (9.2 m)  
Beam – 9'6" (2.9 m)  
Draft – 17" (0.43 m)  
Dry weight (with engines) – 5,300 pounds (2.4 metric tons)  
Bridge clearance with hardtop – 10' (3 m)  
Fuel capacity – 264 gal (1,000 liters)  
Persons capacity – 14  
Water capacity – 20 gal (75 liters)  
Fish box capacity – 464 gal (1,756 liters)  
Maximum HP – Twin 300 HP  
Minimum HP – Twin 150 HP  
Recommended HP – Twin 200 HP  
Cruise speed – 30 – 35 Mph (25 – 30 knots)  
Maximum speed – 50 – 56 Mph (43 – 48 knots)  
Trailer height – 12'6" (3.8 m)

## Standard Equipment

Hand Laid Vinyl Ester Construction for the Deck and Hull  
Foam Floatation, Coast Guard Standard  
Non-skid Self-draining Deck  
Transom Entry Door  
All Hardware is Made of 316-L Thru Bolted Stainless Steel  
Stainless Steel Thru-hull Fittings  
Aluminum/Stainless Grab Rails  
(3) Hydrofoils and Hardware  
(5) Total Dry Storage Areas  
Dry Storage Areas in the Console (lockable)  
Marine Head Electric Flush  
Helm Seats w/4" Cushion & Backrest  
Console Recessed Hand Rails  
Electronics Area that Accommodates two 17" Displays  
LED Navigation Lights  
LED Spreader Lights  
Cockpit Courtesy Lights  
LED Dome Lights  
Horn  
Battery Select Switch  
(3) Battery System  
Enclosed Head/Storage Area in Console w/ Drain  
Marine Head w/Electric Flush (10 Gallon Holding Tank)

(1) Stainless Steel Porthole  
Fiberglass T-top w/ 6 Rod Holders  
Rod Holders (6 on each side of the boat) Port, Starboard, & Gunnels  
Tackle Stations Port/Starboard Gunnels  
(2) Large Fish Boxes – 360 Gallon Aft. Insulated Fish Boxes w/Macerator Pumps  
(2) Storage Compartments – 105 Gallon Port & Starboard Boxes  
4 Automatic Bilge Pumps (Total 4800 GPH)  
(2) Fuel tanks – 200 Gallon Total  
Cockpit Freshwater Shower  
Self-bailing Cockpit w/Cockpit Drains  
Integrated Outboard Mounting System w/Swim Platform  
Starboard and Port Jumpseats Aft.  
Raw Water Wash-down  
Rub Rail - High Density PVC w/Stainless Steel Insert  
Stainless Steel Propellers  
Power Steering System w/ Stainless Steel Tilt Wheel  
(6) Cleats - Flush Mount (pull out)  
Wrap Around Coaming Pads  
(1) Bow Eye  
(2) Stern Eyes  
Anchor Locker w/Drain  
22 lb Danforth Anchor w/15'chain, 300' Anchor Roller w/ Cleat  
40 Gal Livewell Located In Rear of Helm Seat

## Options

LED Underwater Light Package (2)  
Starboard & Port Seating on the Bow  
Fusion Bluetooth Stereo Sound System w/4 Marine Speakers  
Casting Platform Insert w/Cushions  
Hull Color ½  
Hull Color Full  
Hull Matching T-Top Underside Color  
Windshield Wiper/Washer  
Taco 380 Grand Slam Outriggers w/18' Telescoping Poles  
Integrated Battery Charger System  
Lewmar Freefall Windlass w/300' Rode, 15' Chain  
Heavy Duty Stainless Steel Lifting Eye  
Table Option - Bow

# HYSUCAT ADVANTAGES

- Less power required
- Better fuel efficiency
- Longer range
- Stable, smooth and dry ride i
- Improved load carrying capac
- Superior turning capabilitie
- Outstanding sea keeping
- Damping effect reduces fatig
- Extending longevity at sea
- Environmentally friendly: sm
- High speed performance with



# HYSUCAT CC30



# HYSUCAT CC30



HYSUCAT CC 30



# HYSUCAT CC30



# HYSUCAT CC30



HYSUCAT CC30

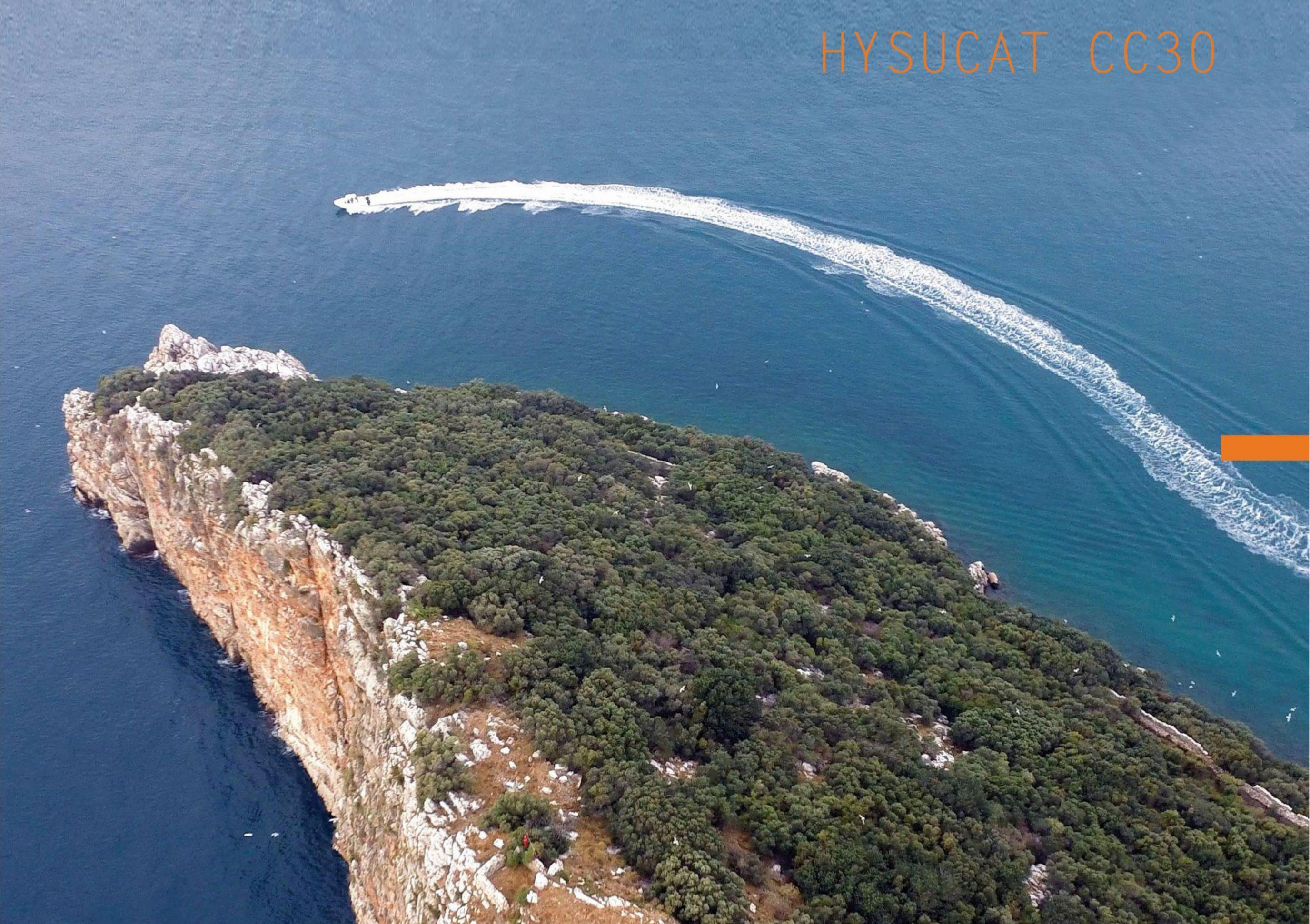

Liman, Free Trade Zone, Antalya, Turkey / E-mail: [info@hysucac.com](mailto:info@hysucac.com) / Tel: + 90(242) 259 46 45, +90(537) 916 44 05  
7013 Hwy 92 East Bath, NC 27808 / E-mail: [info@hysucac.com](mailto:info@hysucac.com) / Tel: 1-252-923-0430  
[www.hysucac.com](http://www.hysucac.com)